

CUSTOMER DRAWING

SPECIFICATIONS ARE SUBJECT TO CHANGE WITHOUT NOTICE

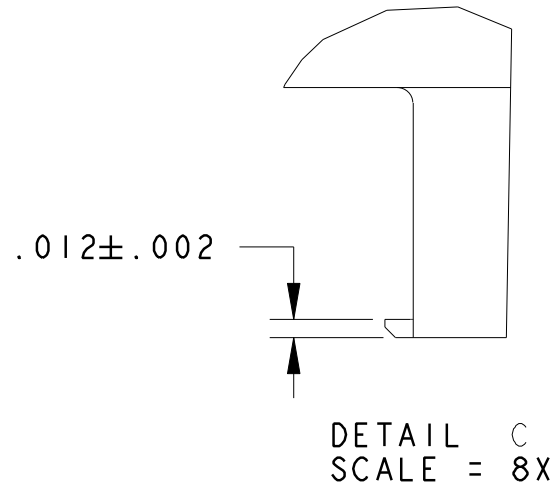
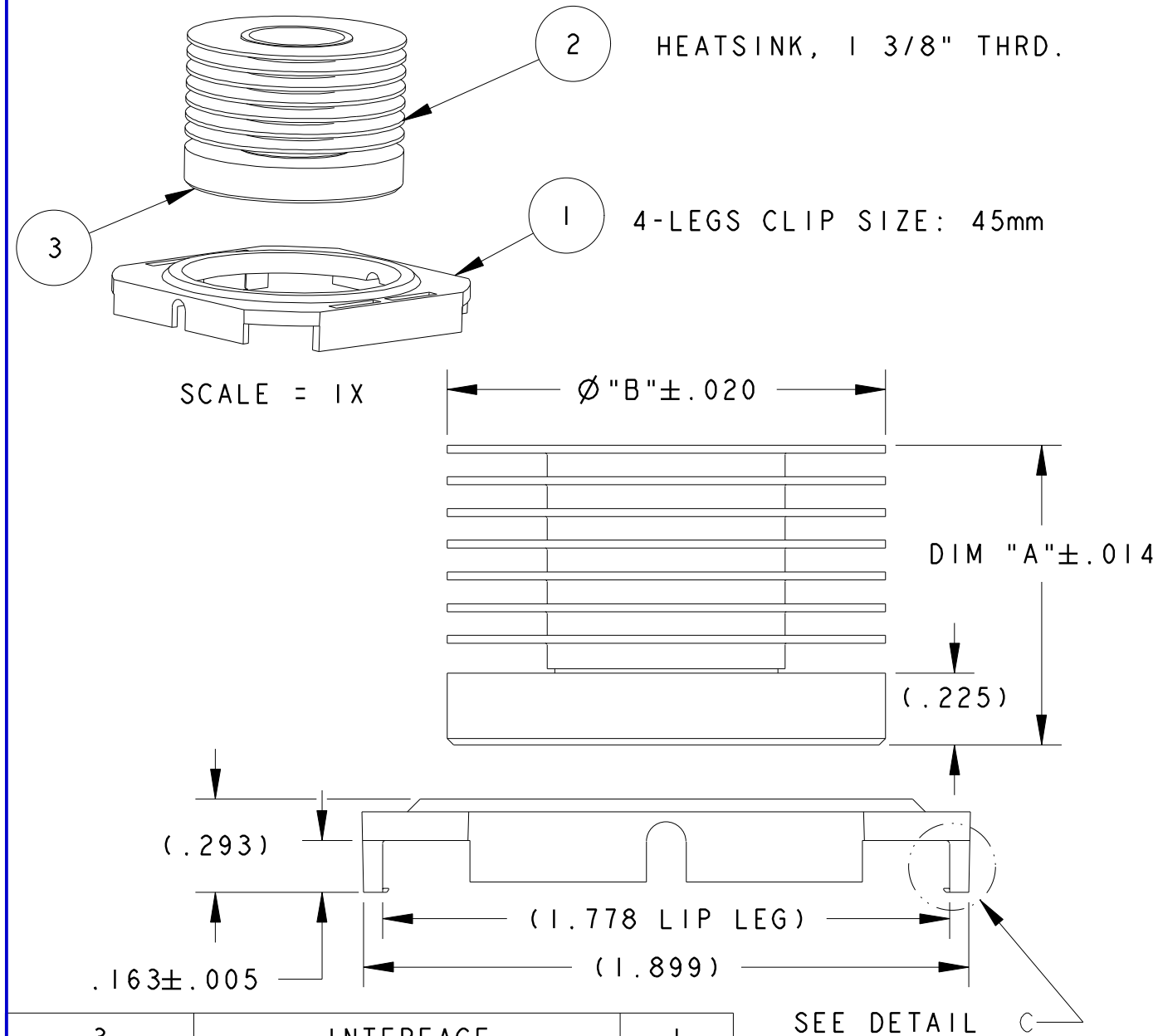

1. MATERIAL:

HEAT SINK: ALUMINUM
CLIP: BLACK PEI (UL94-V0)

2. BEFORE THE HEATSINK APPLICATION, THE USER SHOULD IDENTIFY THE SPECIFICATION OF MAXIMUM LOAD ON THE BGA PACKAGE.

SCREW DRIVER SLOT (.070 WIDE X .100 DEEP) PROVIDED IN THE CENTER PORTION OF THE HEAT SINK. FOR ACCURATE TORQUE SETTING, SCREW DRIVER BIT MUST BE ALIGNED TO THE CENTER LINE OF THE HEAT SINK.

HEATSINK TORQUE SPECIFICATIONS CONVERTED TO FORCE. BARE DIE PACKAGE:

2.5 POUND-FORCE INCH TORQUE = 7.8 POUND-FORCE
(0.28 NEWTON METER TORQUE = 34.70 NEWTON)

3.0 POUND-FORCE INCH TORQUE = 9.4 POUND-FORCE
(0.34 NEWTON METER TORQUE = 41.81 NEWTON)

FULL SIZE LID PACKAGE:

2.5 POUND-FORCE INCH TORQUE = 6.3 POUND-FORCE
(0.28 NEWTON METER TORQUE = 28.02 NEWTON)

3.0 POUND-FORCE INCH TORQUE = 7.6 POUND-FORCE
(0.34 NEWTON METER TORQUE = 33.81 NEWTON)

3. REMOVE CLIP WITH REMOVAL TOOL P/N: 1542616-1

4. RoHS COMPLIANT AND CERTIFIED.

200 LFM	400 LFM	600 LFM				
2.95	2.01	1.58	2-1963563-7	$\varnothing 2.000$ " HS, 1 3/8" THRD. 7 FINS	2.000	.940
3.36	2.23	1.76	2-1963563-5	$\varnothing 2.000$ " HS, 1 3/8" THRD. 5 FINS	2.000	.740
3.67	2.40	1.90	2-1963563-4	$\varnothing 2.000$ " HS, 1 3/8" THRD. 4 FINS	2.000	.640
4.02	2.67	2.12	2-1963563-3	$\varnothing 2.000$ " HS, 1 3/8" THRD. 3 FINS	2.000	.540
4.35	2.98	2.34	2-1963563-2	$\varnothing 2.000$ " HS, 1 3/8" THRD. 2 FINS	2.000	.440
3.67	2.45	1.88	1-1963563-7	$\varnothing 1.375$ " HS, 1 3/8" THRD, 7 FINS	1.375	.940
4.18	2.74	2.11	1-1963563-5	$\varnothing 1.375$ " HS, 1 3/8" THRD, 5 FINS	1.375	.740
4.56	2.95	2.28	1-1963563-4	$\varnothing 1.375$ " HS, 1 3/8" THRD, 4 FINS	1.375	.640
4.98	3.30	2.56	1-1963563-3	$\varnothing 1.375$ " HS, 1 3/8" THRD, 3 FINS	1.375	.540
5.40	3.66	2.84	1-1963563-2	$\varnothing 1.375$ " HS, 1 3/8" THRD. 2 FINS	1.375	.440
Rca ($^{\circ}$ C/WATT)			ASSEMBLY HS PART NO.	DESCRIPTION	\varnothing "B"	DIM "A"
THERMAL PERFORMANCE			TABLE 2			

ITEM NO.	DESCRIPTION	QTY
3	INTERFACE	1
2	HEATSINK, 1 3/8" THRD.	1
1	MOUNTING CLIP	1

TABLE 1 (BOM)

REV.	DESCRIPTION	DATE
A	RELEASE	5-4-07
AI	RELEASED	5-24-07
B	RELEASED	10-18-07
BI	RELEASED	12-14-07

Tyco Electronics North Attleboro, Massachusetts 02760

UNLESS OTHERWISE SPECIFIED TOLERANCES ARE:

DRAWN BY: E. TAO	DATE: 5-4-07
ENGINEER: V. KHEIL	DATE: 5-4-07
FILENAME: C-1963563	PROJECT: PRO-E

MATERIAL: N/A
FINISH: N/A

CONFIDENTIAL PROPERTY OF TYCO ELECTRONICS. NOT TO BE DISCLOSED TO OTHERS. REPRODUCED OR USED FOR ANY PURPOSES EXCEPT AS AUTHORIZED IN WRITING BY AN AUTHORIZED OFFICIAL OF TYCO ELECTRONICS. MUST BE RETURNED TO TYCO ELECTRONICS ON DEMAND, ON COMPLETION OF ORDER OR OTHER PURPOSES FOR WHICH LENT.

TITLE: ASSEMBLY HEATSINK WITH 4 LEGS, 45mm CLIP

TE PART NO.: SEE TABLE 2
DWG. NO.: C-1963563

DIMENSIONS ARE IN: INCHES
SCALE: 2:1
SIZE: B

THIRD ANGLE PROJECTION

SHEET 1 of 1
REV. BI