

NOTES:

1.  $\text{\textcircled{C}}$  REPRESENTS A CRITICAL DIMENSION.
2. MINIMUM PUSH OUT FORCE: 1N [.25 LB]
3. MAXIMUM HEIGHT VARIATION BETWEEN ANY TWO POSTS: 0.13[.005].
4. MAXIMUM ALLOWABLE BOW: 0.05[.002] MM/MM AFTER ASSEMBLY.
5. PARTS TO BE PACKAGED IN TAPE AND REEL.
6. OR-104-01 TO BE COMPRESSED 20-40% TO MEET CEI/IEC 60529 CODE IP67.
7. FOR QUANTITIES UP TO 49 PIECES, NO LEADER, TRAILER, OR REEL WILL BE SUPPLIED.  
FOR QUANTITIES 50-124, NO LEADER OR TRAILER WILL BE SUPPLIED.
8. EPOXY-01 MUST BE FLUSH OR BELOW FORMED BY THIS SURFACE.
9. INSPECT 100% USING GO/NOGO GAUGE, REFER TO PTL.

DESIGNED & DIMENSIONED  
IN MILLIMETERS[INCHES]

MUSBS-05-S-B-TH-XX-TR

No OF POSITIONS  
-05

PACKAGING  
-TR: TAPE & REEL

OPTION  
\* -PF: PANEL FLANGE (LEAVE  
BLANK FOR NO MOUNTING  
HARDWARE)

TERMINATION  
-TH: THROUGH HOLE

PLATING SPECIFICATION  
-S: SELECTIVE, .000030 GOLD  
ON POST, TIN ON TAIL, WITH  
.000050 MIN NICKEL  
UNDERPLATING OVERALL.

TYPE  
-B

\* NOT TOOLED

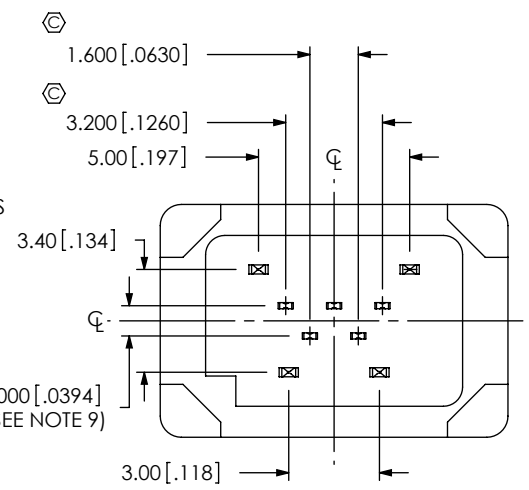
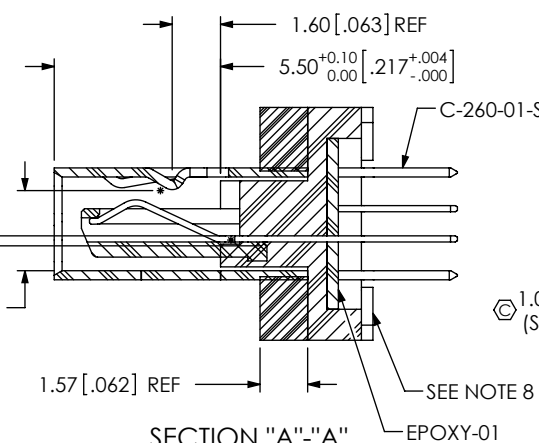
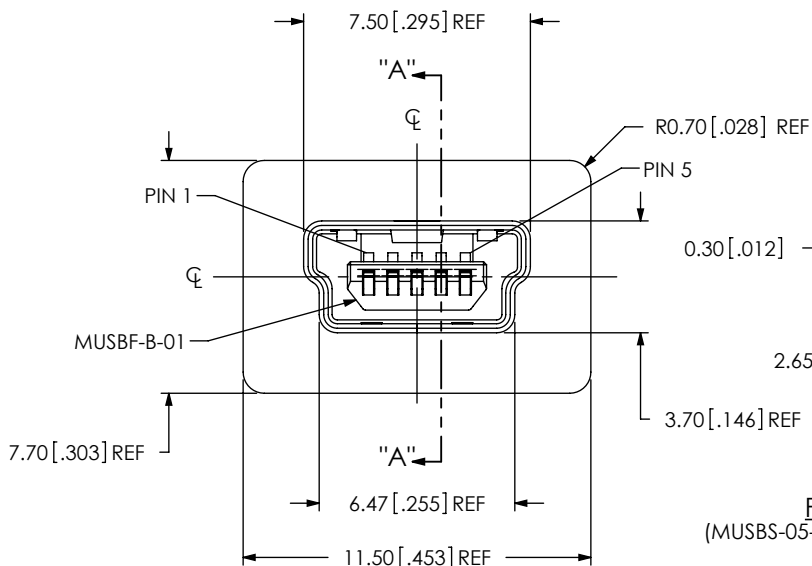
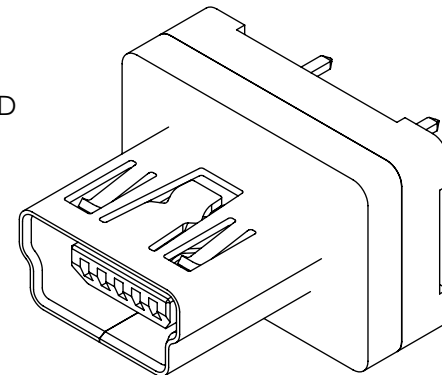
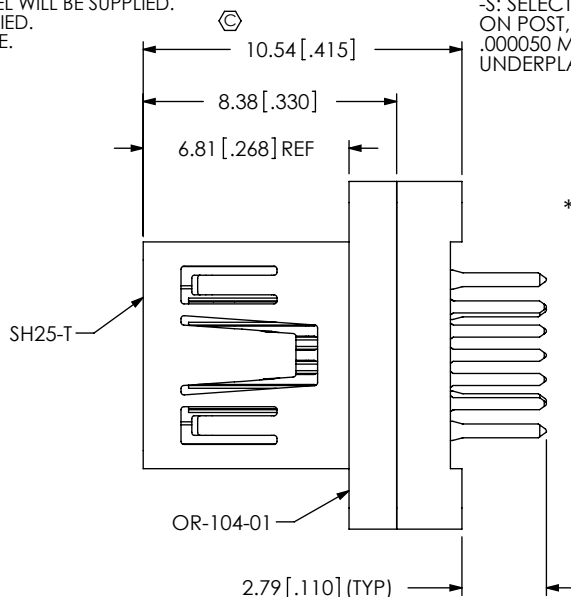
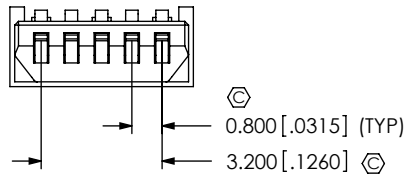
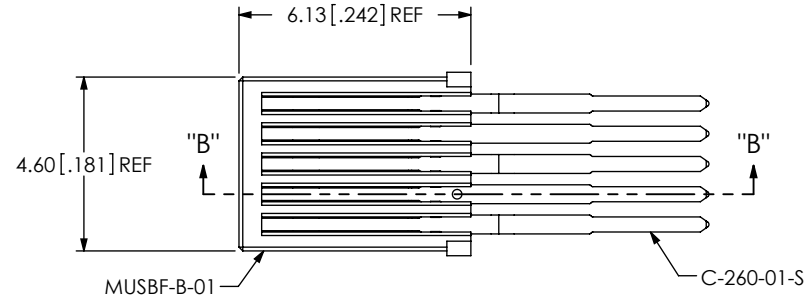
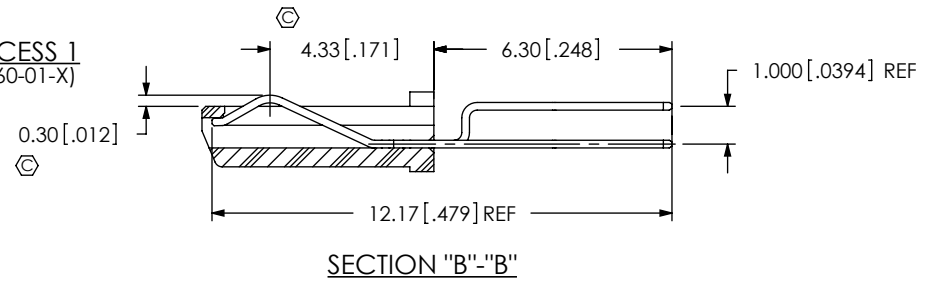

FIG 1  
(MUSBS-05-S-B-TH SHOWN)

<p>UNLESS OTHERWISE SPECIFIED, DIMENSIONS ARE IN MILLIMETERS. TOLERANCES ARE:</p> <p>DECIMALS ANGLES</p> <p>X.X: ±0.3 [.01] 2°</p> <p>X.XX: ±0.13 [.005]</p> <p>X.XXX: ±0.051 [.0020]</p>	<p>PROPRIETARY NOTE</p> <p>THIS DOCUMENT CONTAINS CONFIDENTIAL AND PROPRIETARY INFORMATION AND ALL DESIGN, MANUFACTURING, REPRODUCTION, USE, PATENT RIGHTS AND SALES RIGHTS ARE EXPRESSLY RESERVED BY SAMTEC, INC. THIS DOCUMENT SHALL NOT BE DISCLOSED, IN WHOLE OR PART, TO ANY UNAUTHORIZED PERSON OR ENTITY NOR REPRODUCED, TRANSFERRED OR INCORPORATED IN ANY OTHER PROJECT IN ANY MANNER WITHOUT THE EXPRESS WRITTEN CONSENT OF SAMTEC, INC.</p>	<p>520 PARK EAST BLVD, NEW ALBANY, IN 47150 PHONE: 812-944-6733 FAX: 812-948-5047 e-Mail info@SAMTEC.com code 53322</p>



IN-PROCESS 1  
(FILL C-260-01-X)



IN-PROCESS 2  
(ADD OVERMOLD)

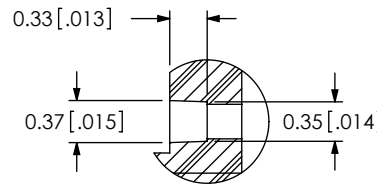
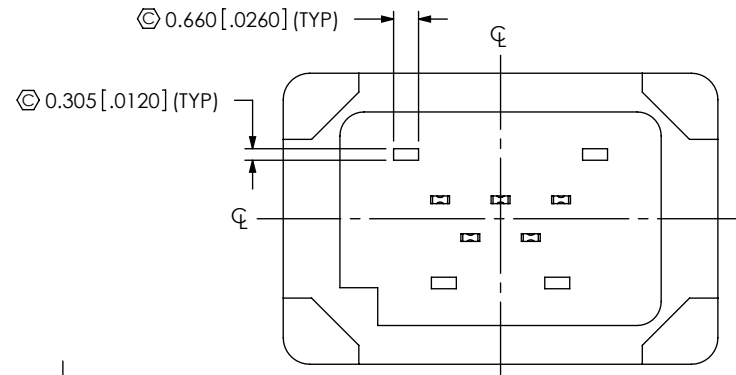
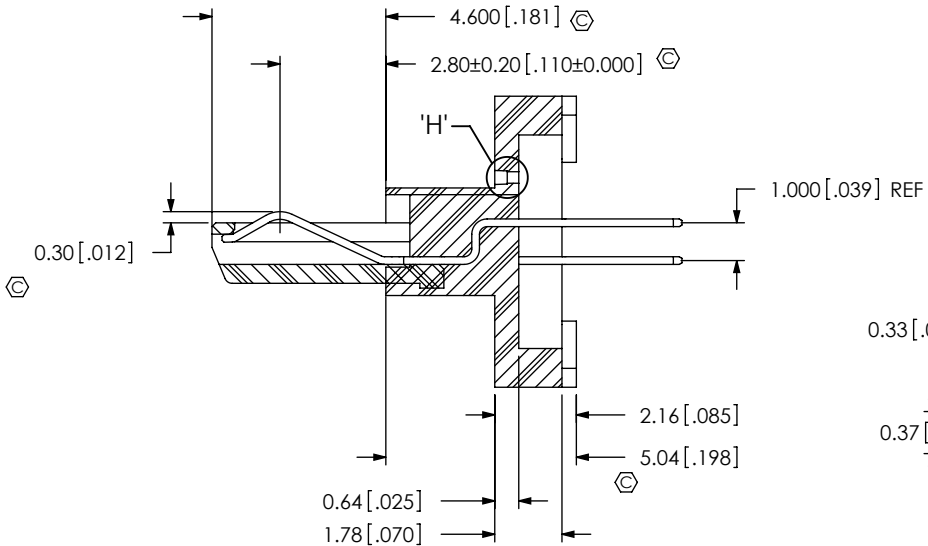
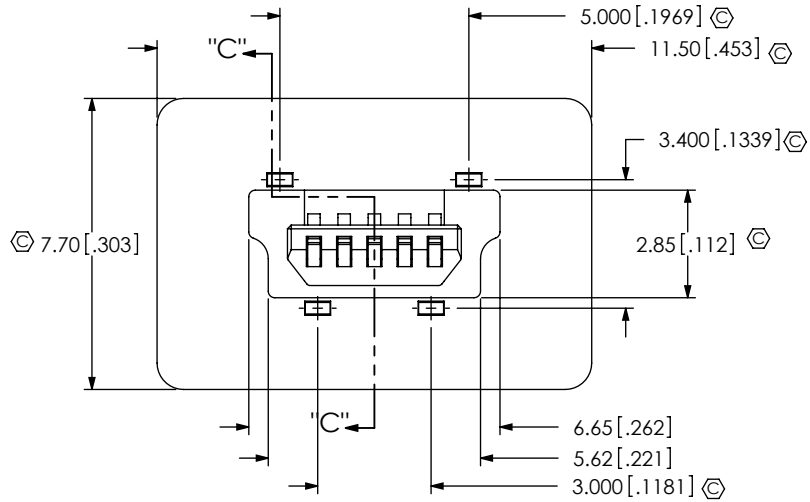

DETAIL "H"  
SCALE 15:1

SECTION "C"- "C"

**PROPRIETARY NOTE**  
THIS DOCUMENT CONTAINS CONFIDENTIAL AND PROPRIETARY INFORMATION AND ALL DESIGN, MANUFACTURING, REPRODUCTION, USE, PATENT RIGHTS AND SALES RIGHTS ARE EXPRESSLY RESERVED BY SAMTEC, INC. THIS DOCUMENT SHALL NOT BE DISCLOSED, IN WHOLE OR PART, TO ANY UNAUTHORIZED PERSON OR ENTITY NOR REPRODUCED, TRANSFERRED OR INCORPORATED IN ANY OTHER PROJECT IN ANY MANNER WITHOUT THE EXPRESS WRITTEN CONSENT OF SAMTEC, INC.

DO NOT SCALE DRAWING

SHEET SCALE: 5:1

**samtec**

520 PARK EAST BLVD, NEW ALBANY, IN 47150  
PHONE: 812-944-6733 FAX: 812-948-5047  
e-Mail info@SAMTEC.com code 55322

DESCRIPTION: MUSB TYPE B, VERTICAL SEALED

DWG. NO. MUSBS-05-S-B-TH-XX-TR

BY: T NEWTON 11/19/2008 SHEET 2 OF 4

IN-PROCESS 3  
(ADD SH25-T)

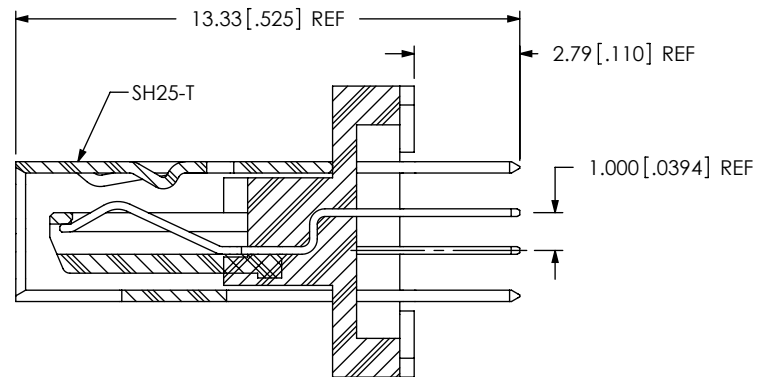
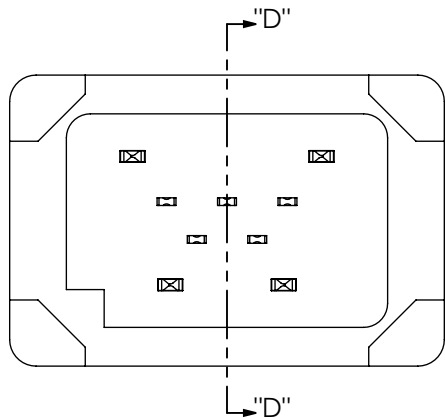

SECTION "D"-"D"

IN-PROCESS 4  
(ADD EPOXY-01)

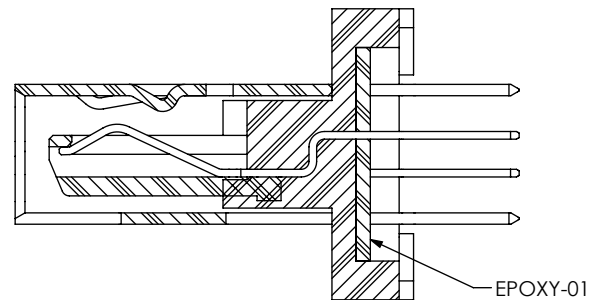
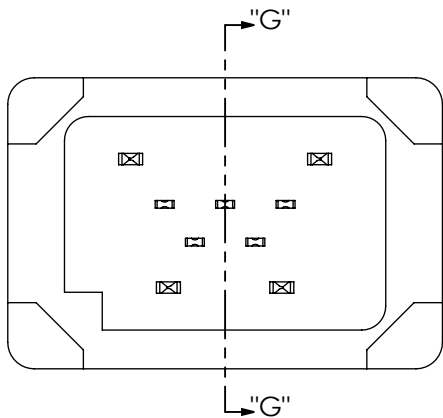

SECTION "G"-"G"

**PROPRIETARY NOTE**  
THIS DOCUMENT CONTAINS CONFIDENTIAL AND PROPRIETARY INFORMATION AND ALL DESIGN, MANUFACTURING, REPRODUCTION, USE, PATENT RIGHTS AND SALES RIGHTS ARE EXPRESSLY RESERVED BY SAMTEC, INC. THIS DOCUMENT SHALL NOT BE DISCLOSED, IN WHOLE OR PART, TO ANY UNAUTHORIZED PERSON OR ENTITY NOR REPRODUCED, TRANSFERRED OR INCORPORATED IN ANY OTHER PROJECT IN ANY MANNER WITHOUT THE EXPRESS WRITTEN CONSENT OF SAMTEC, INC.

DO NOT SCALE DRAWING

SHEET SCALE: 5:1

**samtec**

520 PARK EAST BLVD, NEW ALBANY, IN 47150  
PHONE: 812-944-6733 FAX: 812-948-5047  
e-Mail info@SAMTEC.com code 53322

DESCRIPTION: MUSB TYPE B, VERTICAL SEALED

DWG. NO. MUSBS-05-S-B-TH-XX-TR

BY: T NEWTON 11/19/2008 SHEET 3 OF 4

PACKAGING VIEW

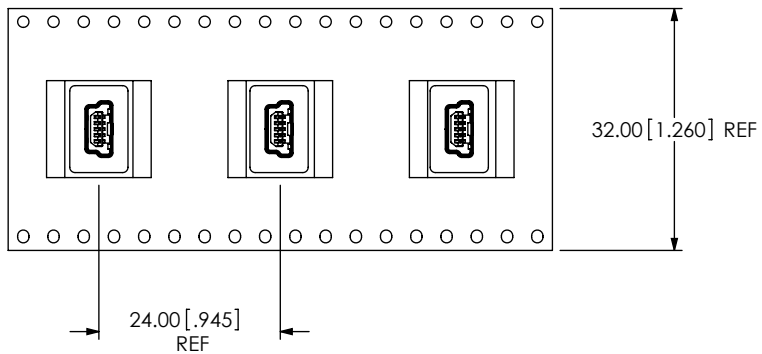

USER DIRECTION OF UN-REELING  
POCKET NOT DETAILED →

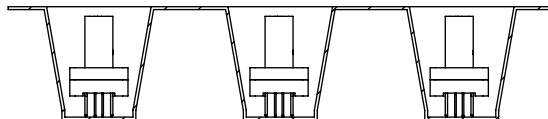

**PROPRIETARY NOTE**  
 \* THIS DOCUMENT CONTAINS CONFIDENTIAL AND PROPRIETARY INFORMATION AND ALL DESIGN, MANUFACTURING, REPRODUCTION, USE, PATENT RIGHTS AND SALES RIGHTS ARE EXPRESSLY RESERVED BY SAMTEC, INC. THIS DOCUMENT SHALL NOT BE DISCLOSED, IN WHOLE OR PART, TO ANY UNAUTHORIZED PERSON OR ENTITY NOR REPRODUCED, TRANSFERRED OR INCORPORATED IN ANY OTHER PROJECT IN ANY MANNER WITHOUT THE EXPRESS WRITTEN CONSENT OF SAMTEC, INC.

DO NOT SCALE DRAWING

SHEET SCALE: 1:1



520 PARK EAST BLVD, NEW ALBANY, IN 47150  
 PHONE: 812-944-6733 FAX: 812-948-5047  
 e-Mail info@SAMTEC.com code 55322

DESCRIPTION: MUSB TYPE B, VERTICAL SEALED

DWG. NO. MUSBS-05-S-B-TH-XX-TR

BY: T NEWTON 11/19/2008 SHEET 4 OF 4